

G**UNIVERSE PLUS
GAS TILTING SKILLET**JOB NAME: _____
ITEM NO.: _____
NO. REQUIRED: _____

- MODELS:**
- 30P-STGL
 - 30P-STGM
- 40P-STGL
 - 40P-STGM

DESCRIPTION:

The Market Forge Gas Universe Plus Tilting Skillets are available in 30-gallon (87-liter) and 40-gallon (114-liter) pan bodies with 93,000 BTU and 126,000 BTU inputs respectively. Both models are available in open-leg and closed-base frame assemblies with manual or power tilt capabilities. The heavy duty construction of our Universe Plus Skillets incorporate sides formed of 10 gage stainless steel and a 5/8" thick stainless steel clad plate that will provide a rigid flat cooking surface with improved heat distribution. The balanced design of the pan allows the operator to easily and quickly tilt to the desired position. Our new power tilt operates smoothly, with manual override that works easily when needed and without the use of tools or drills as required by other manufactures.

CONSTRUCTION: The Universe Plus Skillet has a fully polished stainless steel cooking surface that reduces food from adhering and helps to safely clean the equipment. Gas burners turn off automatically when the cooking pan is tilted from the horizontal position. The skillet is provided with a heavy-duty spring assisted cover and a condensate vent. The cooking pan and cover are supported by two consoles with a fully welded stainless steel tubular frame system that provides stable support to the unit.

The consoles are completely covered with stainless steel that provides protection to the controls and is also easily cleanable and provides clear access for easy floor cleaning. The closed-base model incorporates an easily removable stainless steel front panel. The sloped front of the pan allows for complete draining of the pan when tilted to 70°. The tilting mechanism includes a precision ground and polished worm for smooth and long lasting tilt operation and positive control with a collapsible hand crank. A power tilting option is available and is also supplied with the collapsible handle for manual override operation if required.

TECHNICAL SPECIFICATIONS:

COOKING PAN: The unitized cooking pan with integral clad plate cooking surface is welded with full penetration to resist cracking due to expansion and contraction. The polished cooking surface resists product adherence and improves cleanup and appearance. The pan incorporates an easy-pour lip and elements attached to the bottom of the pan for even and 5-gallon increment markings. The clad plate cooking surface has integrally welded labyrinth fins for positive control and heat trans-

It is our policy to build equipment which is design certified by N.S.F., N.E.M.A. and C.S.A. However, a continuing program of product improvement



30P-STGM Shown

fer from the reliable atmospheric burners. An interlock switch is provided to turn the burners off when the pan is tilted more than 10° from the normal horizontal position. The spring assisted cover with integral vent, condensate drip guide and full width handle affords effortless operation and will maintain an open position.

CONTROLS: The skillet comes standard with a solid-state temperature control with a positive OFF position and 100°-450° Fahrenheit scale, a pilot light to indicate when the burners are ON, spark pilot ignition system as standard and a 1 hour mechanical timer is included. The optional power tilting mechanism also utilizes an UP/DOWN rocker switch. The manual tilting mechanism uses a collapsible hand crank conveniently located below the control panel. The controls are resistant to dripping and light splashing water (NEMA T-2).

OPERATION SHALL BE BY:

The Universe Tilting Plus Skillets models 30P-STGL and 30P-STGM will be rated at 93,000 BTU at 3.5" W.C. natural gas and 10" W.C. propane gas. Models 40P-STGL and 40P-STGM will be rated at 126,000 BTU at 3.5" W.C. natural gas and 10" W.C. propane gas.

CLEARANCE:

LOCATION	12 kW	18 kW
Left Side	0"	0"
Right Side	0"	0"
Back	6"	6"

SPEC SHEET: S-4347
01/08FOOD SERVICE EQUIPMENT
Universe Plus Tilting Skillet

Printed in U.S.A.



35 Garvey Street • Everett • MA • 02149
Tel: (617) 387-4100, (866) 698-3188 • Fax: (800) 227-2659, (617) 387-4456
custserv@mfi.com • www.mfi.com

G**UNIVERSE PLUS
GAS TILTING SKILLET**

JOB NAME: _____

ITEM NO.: _____

NO. REQUIRED: _____

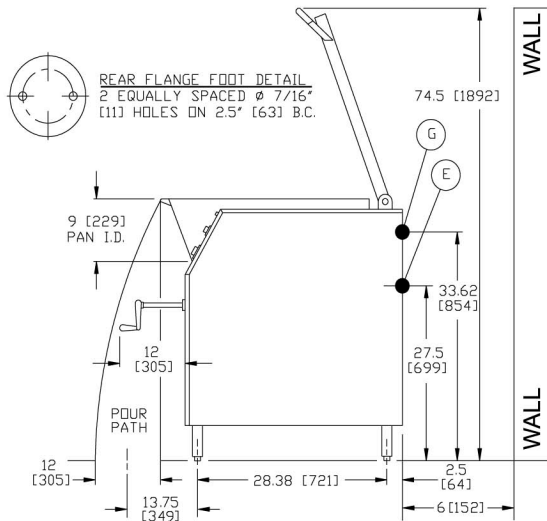
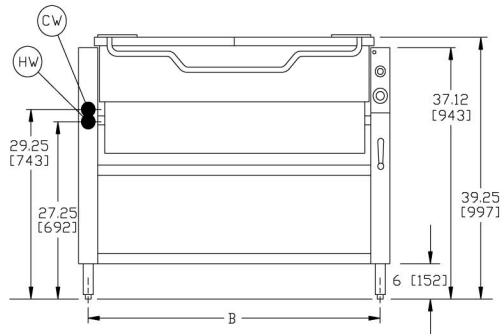
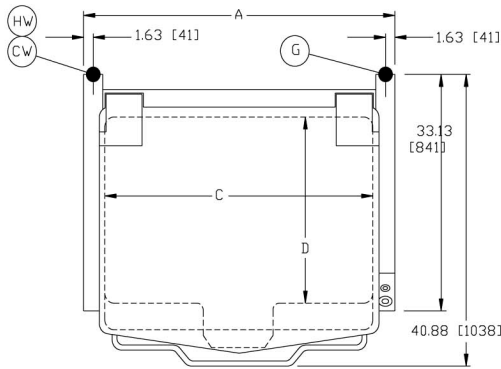
**DIMENSIONS:**

MODEL	CAPACITY		A	B	C	D
30P-STGL 30P-STGM	30 Gallon 114 liter	Inches mm	36 914	34.63 879	30.5 775	25.75 654
40P-STGL 40P-STGM	40 Gallon 152 liter	Inches mm	46 1168	44.63 1133	40.5 1029	25.75 654

The manufacturer reserves the right to modify materials and specifications without notice.

SERVICE CONNECTIONS**Gas Fired:**

G	Gas Connection - Supplied through 3/4" NPT pipe. A gas shut-off valve must be installed in supply piping convenient and adjacent to appliance.
E	Electrical Connection - 120V units supplied with 8' foot cord with 3 prong plug.
CW	Cold Water - 3/8" O.D. NPT to faucet (<i>Optional</i>).
HW	Hot Water - 3/8" O.D. NPT to faucet (<i>Optional</i>).

OPTIONAL AT EXTRA COST:

- Modular Joining Kit
- Pan Support
- Pan Holder Inserts
- Pouring Lip Strainer
- Single Pantry Faucet
- Posi-Set
- 2" Draw-Off Valve w/Strainer
- 2" Tangent Draw-Off Valve w/ Drain Hose Assembly, Includes:
 - 2" Tangent Draw-Off Valve with Strainer
 - 90° Stainless Steel Elbow
 - 8 Foot Long of 2" ID Hose (*cut to required length*)
 - Hose Clamp
- Double Pantry Faucet
- Single Pantry Spray Hose
- Double Pantry Spray Hose
- Castor Kit w/Strain Relief
- Correctional Package
- Drain Cup Assembly, Includes:
 - Stainless Steel Cup Assembly
 - 8' Long of 2" ID Hose (*cut to required length*)
 - Hose Clamp
- Drain Pan Assembly, Includes:
 - 6" x 12" x 20" Stainless Steel Solid Pan w/ Elbow
 - 8' Long of 2" ID Hose (*cut to required length*)
 - Hose Clamp

MANIFOLD GAS PRESSURE AND INPUTS:

	W.C.	30 Gal. BTU	40 Gal. BTU
Natural Spark Pilot	3.5"	93,000	126,000
Propane Spark Pilot	10.0"	93,000	126,000

Note HIGH ALTITUDE - If equipment is to be installed above 2,000 feet specify installation height, so that proper gas orifices can be provided.

SPEC SHEET: S-4347
01/08FOOD SERVICE EQUIPMENT
Universe Plus Tilting Skillet