

E

**4, 6, 10 & 12 GALLON
SELF-CONTAINED ELECTRIC KETTLE
WITH HAND CRANK**

JOB NAME: _____

ITEM NO.: _____

NO. REQUIRED: _____

CAPACITY

MODEL	CAPACITY		A	B	C	D	E	F	G	H	J	K	L	M
FCT-4CE	4 Gal. 16 Liters	in mm	12 305	--	--	15 387	25 638	4 102	28 711	6 1/8 156	13 330	12 3/4 324	10 254	6 1/8 156
FCT-6CE	6 Gal. 23 Liters	in mm	12 305	14 356	25 638	15 387	25 638	4 102	28 711	6 1/8 156	13 330	12 3/4 324	10 254	6 1/8 156
FCT-10CE	10 Gal. 38 Liters	in mm	16 406	15 381	25.5 648	19 486	28 7/8 734	4 102	28 711	6 1/8 156	13 330	12 3/4 324	12 3/4 324	6 1/8 156
FCT-12CE	12 Gal. 45 Liters	in mm	16 406	17 432	27.5 699	19 486	28 7/8 734	4 102	30 762	6 1/8 156	13 330	12 3/4 324	12 3/4 324	6 1/8 156

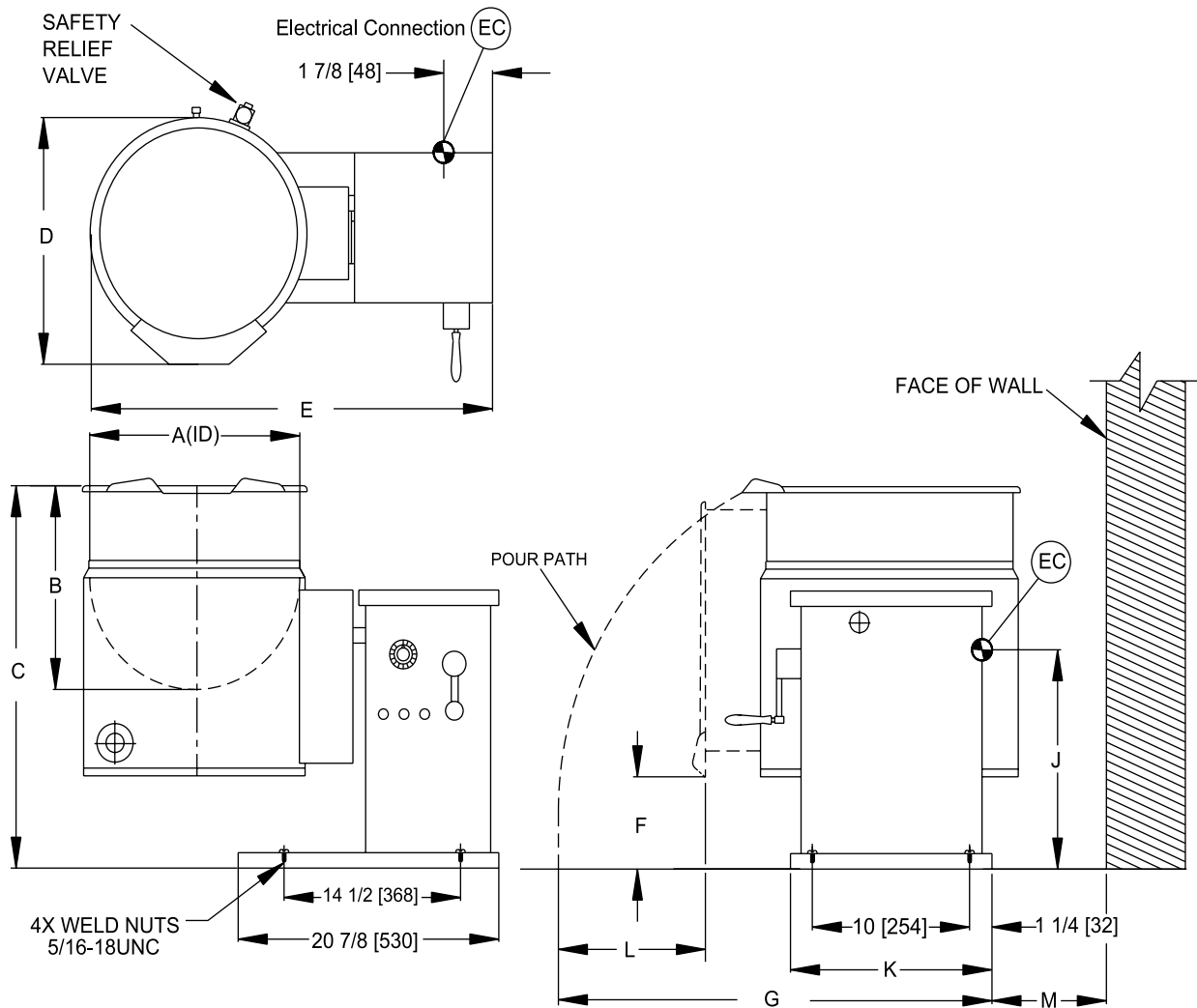
SPEC SHEET: S-4864B
07/06FOOD SERVICE EQUIPMENT
Countertop Kettle

*It is our policy to build equipment which is design certified by U.L., N.S.F. and C.S.A. However, a continuing program of product improvement makes it necessary to submit new models to the agencies as they are developed and consequently not all models bear the appropriate agency labels at all times.



MARKET FORGE
INDUSTRIES INC.
An Employee Owned Company



PRINTED IN U. S. A.

35 Garvey Street • Everett • MA • 02149
Tel: (617) 387-4100 • Fax: 1-800-227-2659 (Ex. MA) • (617) 387-4456 (MA and Overseas)
E-Mail: CUSTSERV@mfi.com • Website: www.mfii.com