

**E****ELECTRIC COUNTER-TOP  
CONVECTION STEAMER**JOB NAME: \_\_\_\_\_  
ITEM NO.: \_\_\_\_\_  
NO. REQUIRED: \_\_\_\_\_

- MODELS:**
- 
- PS-3E
- 
- PS-6E

- SIZE:**
- 
- PS-3E**
- 
- 24" Wide x 15" High x 27.5" Front-to-Back
- 
- (610mm Wide x 381mm High x 698mm Front-to-Back)
- 
- PS-6E**
- 
- 24" Wide x 21.6" High x 27.5" Front-to-Back
- 
- (610mm Wide x 549mm High x 698mm Front-to-Back)



PS-3E



PS-6E

**DESCRIPTION:**

The Market Forge Counter-Top Convection Steamer with Electric Steam Generator shall be constructed of satin finish stainless steel, type 304 with a cooking chamber of one-piece all welded stainless steel, type 316 with coved corners. The door shall have a removable inner liner of stainless steel with full perimeter gasket seal, an outer liner of one-piece all welded stainless steel and a positive lock and seal mechanism with spring release. The steamer shall be constructed to be mounted flush to counter-top or on standard 4" legs and to be placed side by side or stacked using an optional stacking kit. The counter-top electric convection steamer shall be provided with removable stainless steel pan supports and a stainless steel drip trough integrally connected to the drain to collect condensation when door is opened.

The control housing shall be constructed of stainless steel with a full access removable panel. The controls include an illuminated three way on/off/delime power switch, pilot ready light, 60 minute electric timer which sounds an audible signal at the end of each cooking cycle and solid state generator controls. Steam flow to the cooking chamber shall be interrupted when the door is opened during the cook cycle and shall be reactivated when the door is closed.

Standard features include a delimiting port which is located at the rear of the unit for easy access to allow cleaning of the generator, delimiting mode power setting, 4" adjustable legs, continuous steam feature, automatic blow-down valve, solid state liquid level controls, and split water connections (for simple hook up to a water treatment system).

The manufacturer reserves the right to modify materials and specifications without notice.

**STANDARD FEATURES:**

Electrically heated steam generator operating at 0 PSI (0kg/cm<sup>2</sup>) with field replaceable elements rated at:

- 10 kW - PS-3E
- 15 kW - PS-6E

The steam boiler shall be equipped for operation on:

- 208 VAC, 3 Phase, 50/60 Hz.\*
- 220 VAC, 3 Phase, 50/60 Hz.\*
- 240 VAC, 3 Phase, 50/60 Hz.\*
- 380/220 VAC, 3 Phase, 50/60 Hz, 4 Wire.
- 415/240 VAC, 3 Phase, 50/60 Hz, 4 Wire.

**OPTIONAL AT EXTRA COST:**

- Stacking Kit.
- Stacking Stand (18" High).
- Stand (28" High).
- Stand (34" High).
- Correctional Package.
- High Sensitivity Level Controls (R.O. Water).
- 380 VAC, 3 Phase, 50/60 Hz.
- 415 VAC, 3 Phase, 50/60 Hz.
- 480 VAC, 3 Phase, 50/60 Hz.
- 600 VAC, 3 Phase, 50/60 Hz.

SPEC SHEET: S-4797  
04/06**FOOD SERVICE EQUIPMENT**  
Electric Steamer**MARKET FORGE**  
INDUSTRIES INC.  
An Employee Owned Company35 Garvey Street • Everett • MA • 02149  
Tel: (617) 387-47100 • Fax: 1-800-227-2659 (Ex. MA) • (617) 387-4456 (MA and Overseas)  
E-Mail: CUSTSERV@mfi.com • Website: www.mfi.com

# E

## ELECTRIC COUNTER-TOP CONVECTION STEAMER

### DETAILS & DIMENSION

#### SERVICE CONNECTIONS

##### Electrically Operated

EC	Electrical Connection - 1 <sup>1</sup> / <sub>8</sub> " (29mm) electric connection to controls.
D	Drain - 1" (25mm) IPS piped to open floor drain. NO SOLID CONNECTION TO FLOOR DRAIN. NO BENDS OR ELBOWS.
CW	Cold Water - 3/8" (10mm) OD tubing at 25-50 PSI.
GW	Generator Water - 3/8" (10mm) OD tubing at 25-50 PSI.

#### CAUTION:

Before connecting water to this unit, water supply should be analyzed to make sure hardness is no greater than 2.0 grains and pH level is within the range of 7.0-8.5. Water which fails to meet these standards should be treated by installation of water conditioner. **EQUIPMENT FAILURE CAUSED BY INADEQUATE WATER QUALITY IS NOT COVERED UNDER WARRANTY.**

#### PAN CAPACITIES

Size	1"	2.5"	4"	6"
PS-3E	6	3	2	1
PS-6E	12	6	3	2

MODEL	KW	AMP/PHASE								
		SINGLE PHASE			THREE PHASE					
		208	220	240	208	240	380	415	480	600
PS-3E	10	48	46	42	28	24	16	14	12	10
PS-6E	15	72	69	63	42	36	23	21	18	15

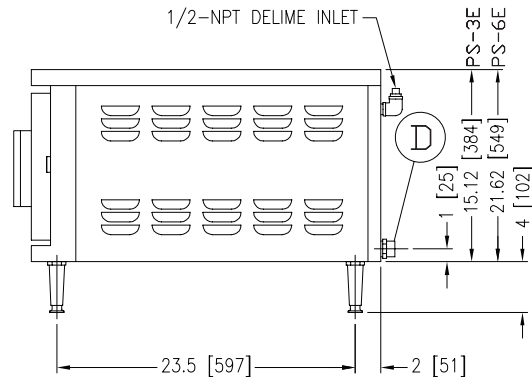
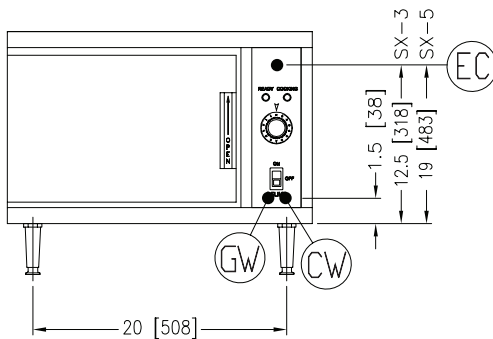
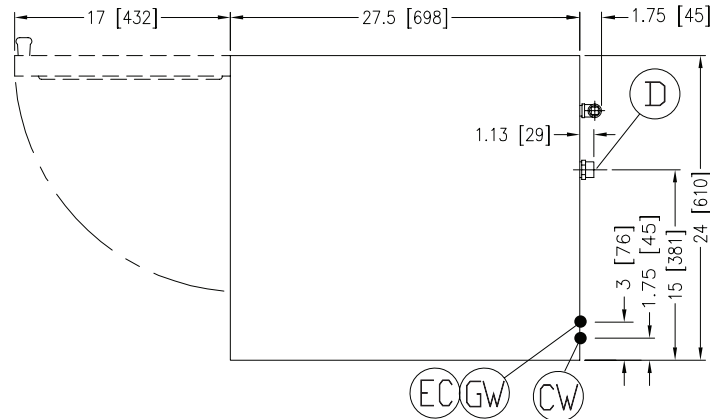

\*It is our policy to build equipment which is design certified by U.L., N.S.F. and C.S.A. However, a continuing program of product improvement makes it necessary to submit new models to the agencies as they are developed and consequently not all models bear the appropriate agency labels at all times.

SPEC SHEET: S-4797 04/06

FOOD SERVICE EQUIPMENT  
Electric Steamer



**MARKET FORGE**  
INDUSTRIES INC.  
An Employee Owned Company



PRINTED IN U. S. A.

35 Garvey Street • Everett • MA • 02149  
Tel: (617) 387-47100 • Fax: 1-800-227-2659 (Ex. MA) • (617) 387-4456 (MA and Overseas)  
E-Mail: CUSTSERV@mfi.com • Website: www.mfi.com