

Item # _____



RIB Infrared Radiant Broilers



Standard Features:

- ◆ Stainless steel sides and front
- ◆ Stainless steel landing ledge on the front.
- ◆ Heavy cast iron reversible top grates.
- ◆ Infra-Red burners rated at 35,000 B.T.U. per hour each.
- ◆ Heavy gauge welded fire box.
- ◆ Easily removable heavy gauge welded stainless steel radiants.
- ◆ Standing pilot for instant ignition.
- ◆ Individual burner control.
- ◆ 4" high adjustable heavy duty appliance legs included.

RIB-36
Shown
With Optional Splash Guard

Options:

- ◆ Stainless steel fire box.
- ◆ Stainless steel splash guard, tapered to front.
- ◆ Stainless steel stand with adjustable bullet feet.
- ◆ Casters (2 locking, 2 non locking) for the stand.
- ◆ Smoker box for wood flavor cooking.



Innovative design of Baffles stops food debris from reaching Infrared Burners but allows intense heat to cook food to perfection.

This series of radiant broilers uses infrared burners rated at 35,000 BTU each for 50% faster heat up, even distribution and rapid recovery. Moreover this efficient technology combined with an isolated fire box maintains the heat in the cooking area while keeping the sides and rear much cooler. Designed for fast and easy cleanup, minimizing down time.



Infrared Radiant Broiler Specifications

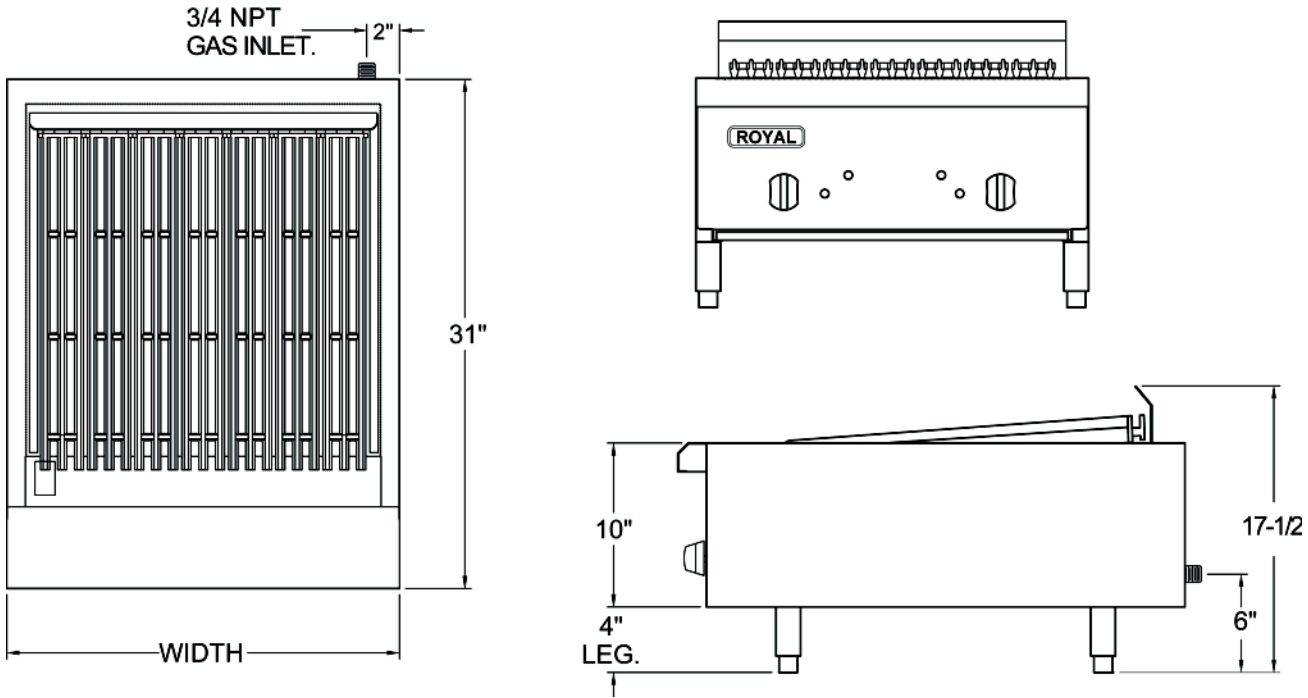

Model	Width	Depth	Broiling Grid	Infra-Red Burners	Total BTU	Ship Weight
RIB-24	24"	31"	21-1/2" x 20"	2	70,000	160 lbs
RIB-36	36"	31"	21-1/2" x 32"	3	105,000	204 lbs
RIB-48	48"	31"	21-1/2" x 44"	4	140,000	260 lbs
RIB-60	60"	31"	21-1/2" x 56"	5	175,000	325 lbs

Gas Connection: 3/4" NPT on the right hand rear of the appliance
 The pressure regulator (supplied) is to be connected here by the installer.

Gas pressure: 5" W.C. - Natural Gas
 10" W.C. - Propane

Combustible Clearances:
 For use only in
 non-combustible locations

Non-combustible Clearances:
 0 inches sides
 0 inches rear

Specify type of gas and altitude,
 if over 2,000 feet, when ordering.

Due to continuing product development to ensure best possible performance, these specifications are subject to change without prior notification