

Item # _____



RRB / RSRB

Radiant Broilers, Combinations



RRB-24 Shown

STANDARD FEATURES:

- ◆ Compact heavy gauge chassis for long life.
- ◆ Stainless steel sides and front valve cover.
- ◆ Double wall panels for better insulation.
- ◆ All welded fire box supports heavy duty radiant covers.
- ◆ Steel tubular burners rated at 15,000 BTU/hr. in the heavy duty and combo (RRB) models, at 12,500 BTU/ hr. for the snack (RSRB) models.
- ◆ Open burners feature two piece lift off tops of heavy cast iron rated at 30,000 BTU / Hr.
- ◆ All burners are controlled by individual valves and each one has a standing pilot for rapid and safe ignition.
- ◆ Heavy duty cast iron top grates.
- ◆ Full width removable crumb pan under the broiler, with a separate pan under the open burner section in the combination models.
- ◆ Full width heavy stainless steel plate ledge complements the work surface and aids in food handling.
- ◆ 4" high adjustable heavy duty legs included.

OPTIONS:

- ◆ Round rod grate for the broiler section.
- ◆ 10" diameter Stainless Steel wok rings to fit on top grate for open burners.
- ◆ Interchangeable wok or saute burner heads for open burners.
- ◆ Stainless steel stand with adjustable legs.
- ◆ Casters for stand.
- ◆ Stainless Steel splash guard, up to 12" high, sides tapered to 4" in front.

Royal Radiant Broilers meet the need for high performance underfired cooking.

Heavy-Duty and Snack radiant broilers come with heavy cast iron radiants and tubular steel burners.

Quality insulated chassis and burner placement ensure even heat distribution. Standard cast iron top grate configuration gives the operator flexibility to cook rare, medium and well-done food simultaneously.

Combination units add two or four open top burners to increase efficiency and add flexibility for the crowded kitchen facility.



Radiant Broiler Specifications

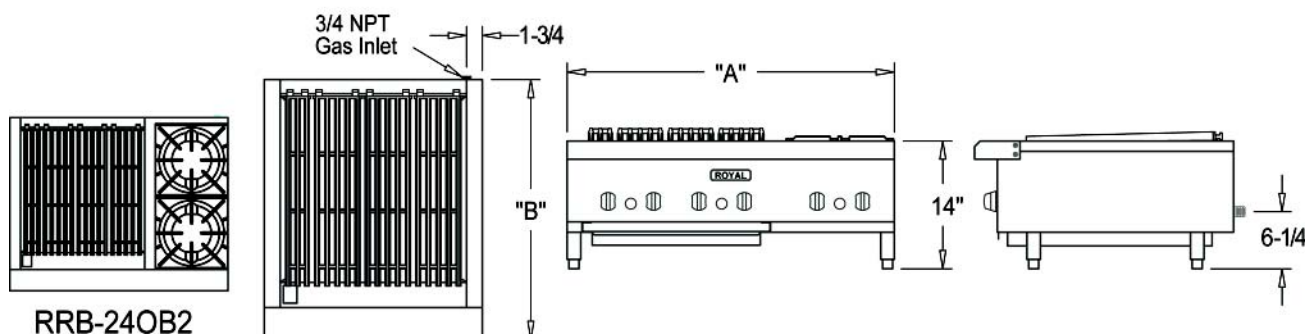

RRB-24OB2

<i>Snack Radiant Broiler</i>					
MODEL NO.	WIDTH (A)	DEPTH (B)	NUMBER OF BURNERS *	TOTAL BTU	SHIP WEIGHT
RSRB-12	12"	26"	1	12,500	113 Lbs.
RSRB-18	18"	26"	3	37,500	150 Lbs.
RSRB-24	24"	26"	4	50,000	197 Lbs.
RSRB-30	30"	26"	5	62,500	260 Lbs.
RSRB-36	36"	26"	6	75,000	311 Lbs.
RSRB-48	48"	26"	8	100,000	365 Lbs.
* Snack Radiant Burner(s) @ 12,500 BTU/hr. each					
<i>Heavy Duty Radiant Broiler</i>					
MODEL NO.	WIDTH (A)	DEPTH (B)	NUMBER OF BURNERS *	TOTAL BTU	SHIP WEIGHT
RRB-12	12"	29-3/4"	1	15,000	170 Lbs.
RRB-18	18"	29-3/4"	3	45,000	235 Lbs.
RRB-24	24"	29-3/4"	4	60,000	300 Lbs.
RRB-30	30"	29-3/4"	5	75,000	340 Lbs.
RRB-36	36"	29-3/4"	6	90,000	383 Lbs.
RRB-48	48"	29-3/4"	8	120,000	460 Lbs.
RRB-60	60"	29-3/4"	10	150,000	510 Lbs.
RRB-72	72"	29-3/4"	12	180,000	670 Lbs.
* Radiant Burner(s) @ 15,000 BTU/hr. each					
<i>Radiant Broiler Hot Plate Combinations</i>					
MODEL NO.	WIDTH (A)	DEPTH (B)	NUMBER OF BURNERS *	TOTAL BTU	SHIP WEIGHT
RRB-12OB2	24"	29-3/4"	1R / 2 OB	75,000	255 Lbs.
RRB-18OB2	30"	29-3/4"	3R / 2 OB	105,000	330 Lbs.
RRB-24OB2	36"	29-3/4"	4R / 2 OB	120,000	395 Lbs.
RRB-24OB4	48"	29-3/4"	4R / 4 OB	180,000	455 Lbs.
RRB-30OB2	42"	29-3/4"	5R / 2 OB	135,000	435 Lbs.
RRB-30OB4	54"	29-3/4"	5R / 4 OB	195,000	495 Lbs.
RRB-36OB2	48"	29-3/4"	6R / 2 OB	150,000	480 Lbs.
* R=Radiant Burner(s) @ 15,000 BTU/hr. each / OB=Open Burners @ 30,000 BTU/hr. each					

Gas Connection: 3/4" NPT on the right hand rear of the appliance
 The pressure regulator (supplied) is to be connected here by the installer.

Gas pressure: 5" W.C. - Natural Gas
 10" W.C. - Propane

Combustible Clearances: For use only in non-combustible locations
Non-combustible Clearances: 0 inches sides
 0 inches rear

Specify type of gas and altitude, if over 2,000 feet, when ordering.

Due to continuing product development to ensure best possible performance, these specifications are subject to change without prior notification