

Item # _____



RVB Vertical Rotisserie Broiler

STANDARD FEATURES:

- ◆ All heavy duty stainless steel front and sides.
- ◆ Double side panels for better insulation.
- ◆ Specially designed Infrared burners rated @ 13,000 BTU/hr. each.
- ◆ Burners are equipped with two continuous pilots for instant ignition.
- ◆ Adjustable side baffles for directional control of heat.
- ◆ Skewer position adjustable front to back.
- ◆ 12" round grease catch pan at the bottom of the skewer.
- ◆ 2 Manual controls to operate each burner separately.



RVB-2

Royal Vertical Rotisseries are user friendly, designed to last and easy to clean. They are made of heavy gauge stainless steel with double side panels for better insulation. A standing pilot light for each burner provides safe ignition.



Vertical Rotisserie Broiler Specifications

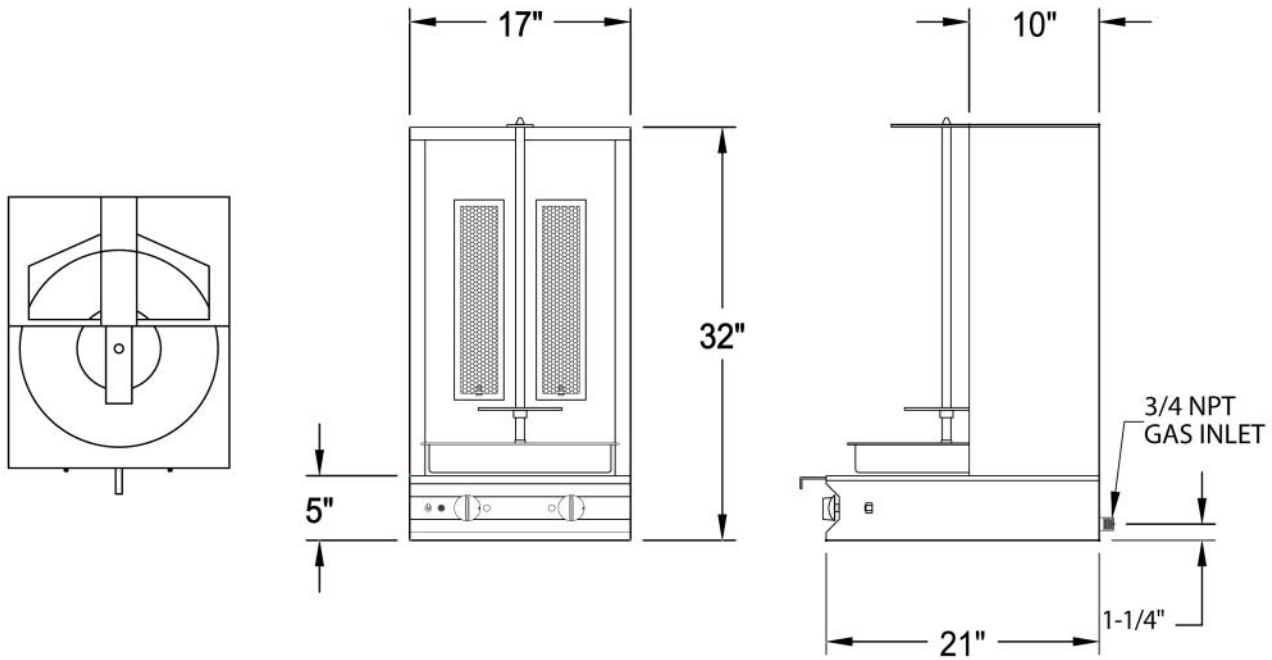

MODEL NO.	WIDTH	DEPTH	NUMBER OF BURNERS	TOTAL BTU	SHIP WEIGHT
RVB-2	17"	21"	2	26,000	75 Lbs.

Gas Connection: 3/4" NPT on the right hand rear of the appliance
 The pressure regulator (supplied) is to be connected here by the installer.

Gas pressure: 5" W.C. - Natural Gas
 10" W.C. - Propane

Combustible Clearances:
 14 inches sides
 2 inches rear

Non-combustible Clearances:
 0 inches sides
 0 inches rear

Specify type of gas and altitude,
 if over 2,000 feet, when ordering.

Due to continuing product development to ensure best possible performance, these specifications are subject to change without prior notification