



TRUE FOOD SERVICE EQUIPMENT, INC.

St. Charles Industrial Center • P.O. Box 970 • O'Fallon, Missouri 63366
 (636)240-2400 • FAX (636)272-2408 • (800)325-6152 • www.truemfg.com
 Parts Dept. (800)424-TRUE • Parts Dept. FAX# (636)272-9471

Project Name: _____

A/A #

Location: _____

Item #: _____ Qty: _____

SIS #

Model #: _____

Model:
T-49G-4

T Series:
Reach-In Glass Half Door Refrigerator



T-49G-4

- ▶ True's glass door reach-in's are designed with enduring quality that protects your long term investment.
 - ▶ Designed using the highest quality materials and components to provide the user with colder product temperatures, lower utility costs, exceptional food safety and the best value in today's food service marketplace.
 - ▶ Oversized, factory balanced, refrigeration system holds 33°F to 38°F (.5°C to 3.3°C) for the best in food preservation.
 - ▶ Energy efficient, "Low-E", double pane thermal glass door.
 - ▶ Patented intergrated door light (IDL) system for high product visibility.
 - ▶ Adjustable, heavy duty PVC coated shelves.
 - ▶ Positive seal self-closing door. Lifetime guaranteed door hinges and torsion type closure system.
- Bottom mounted units feature:**
- ▶ "No stoop" lower shelf.
 - ▶ Storage on top of cabinet.
 - ▶ Compressor performs in coolest, most grease free area of kitchen.
 - ▶ Easily accessible condenser coil for cleaning.

ROUGH-IN DATA

Specifications subject to change without notice.

Chart dimensions rounded up to the nearest 1/8" (millimeters rounded up to next whole number).

Model	Doors	Capacity (Cu. Ft.) (liters)	Shelves	Cabinet Dimensions (inches) (mm)			HP	Voltage	Amps	NEMA Config.	Cord Length (total ft.) (total m)	Crated Weight (lbs.) (kg)
				L	D†	H*						
T-49G-4	4	49 1388	6	54 ¹ / ₈ 1375	29 ³ / ₄ 756	78 ³ / ₈ 1991	1/2 1/2	115/60/1 230-240/50/1	9.1 5.4	5-15P ▲	9 2.74	490 223

† Depth does not include 1³/₈" (35 mm) for door handles.

▲ Plug type varies by country

* Height does not include 5" (127 mm) for castors or 6" (153 mm) for optional legs.



APPROVALS:

AVAILABLE AT:

Model:
T-49G-4

T Series:
Reach-In Glass Half Door Refrigerator



STANDARD FEATURES

DESIGN

- True's commitment to using the highest quality materials and oversized refrigeration systems provides the user with colder product temperatures, lower utility costs, exceptional food safety and the best value in today's food service marketplace.

REFRIGERATION SYSTEM

- Factory engineered, self-contained, capillary tube system using environmentally friendly (CFC free) 134A refrigerant.
- Extra large evaporator coil balanced with higher horsepower compressor and large condenser; maintains 33°F to 38°F (.5°C to 3.3°C) for the best in food preservation.
- Sealed, cast iron, self-lubricating evaporator fan motor and larger fan blades give True reach-in's a more efficient low velocity, high volume airflow design. This unique design insures faster temperature recovery and shorter run times in the busiest of foodservice environments.
- Bottom mounted condensing unit positioned for easy maintenance. Compressor runs in coolest and most grease free area of the kitchen. Allows for storage area on top of unit.

CABINET CONSTRUCTION

- Exterior - 300 series stainless steel front grill and shroud. Anodized quality aluminum exterior ends and back.

- Interior - attractive, NSF approved, white aluminum liner. 300 series stainless floor with coved corners.
- Insulation - entire cabinet structure is foamed-in-place using high density, CFC free, polyurethane insulation.
- Welded, heavy duty galvanized frame rail dipped in rust inhibiting enamel paint for corrosion protection inside and out.
- Frame rail fitted with 4" (102 mm) diameter stem castors - locks provided on front set.

DOORS

- "Low-E", double pane thermal glass assemblies with extruded aluminum frames. Door locks standard.
- Each door fitted with 15" (381 mm) long extruded aluminum handle.
- Positive seal self-closing doors. Lifetime guaranteed door hinges and torsion type closure system.
- Magnetic door gaskets of one piece construction, removable without tools for ease of cleaning.

SHELVING

- Six (6) adjustable, heavy duty PVC coated wire shelves 24⁹/₁₆" L x 20³/₄" D (624 mm x 528 mm). Four (4) chrome plated shelf clips included per shelf.
- Shelf support pilasters made of same material as cabinet interior; shelves are adjustable on 1/2" (13 mm) increments.

LIGHTING

- Fluorescent interior lighting. Each door utilizes full-length, patented, integrated door light (IDL) system. Safety shielded.

MODEL FEATURES

- Exterior mounted temperature monitor.
- Evaporator is epoxy coated to eliminate the potential of corrosion.
- NSF-7 compliant for open food product.

ELECTRICAL

- Unit completely pre-wired at factory and ready for final connection to a 115/60/1 phase - 15 amp dedicated outlet. Cord and plug set included.



115/60/1
NEMA-5-15R

OPTIONAL FEATURES/ACCESSORIES

Upcharge and lead times may apply.

- 230 - 240V / 50 Hz.
- 6" (153 mm) standard legs.
- 6" (153 mm) seismic/flanged legs.
- Additional shelves.
- Alternate door hinging (factory installed).
- Half door bun tray racks. Each holds up to eleven 18" L x 26" D (458 mm x 661 mm) sheet pans (sold separately).
- Remote cabinets (condensing unit supplied by others; system comes standard with 404A expansion valve and requires R404A refrigerant). Consult factory technical service department for BTU information.

PLAN VIEW

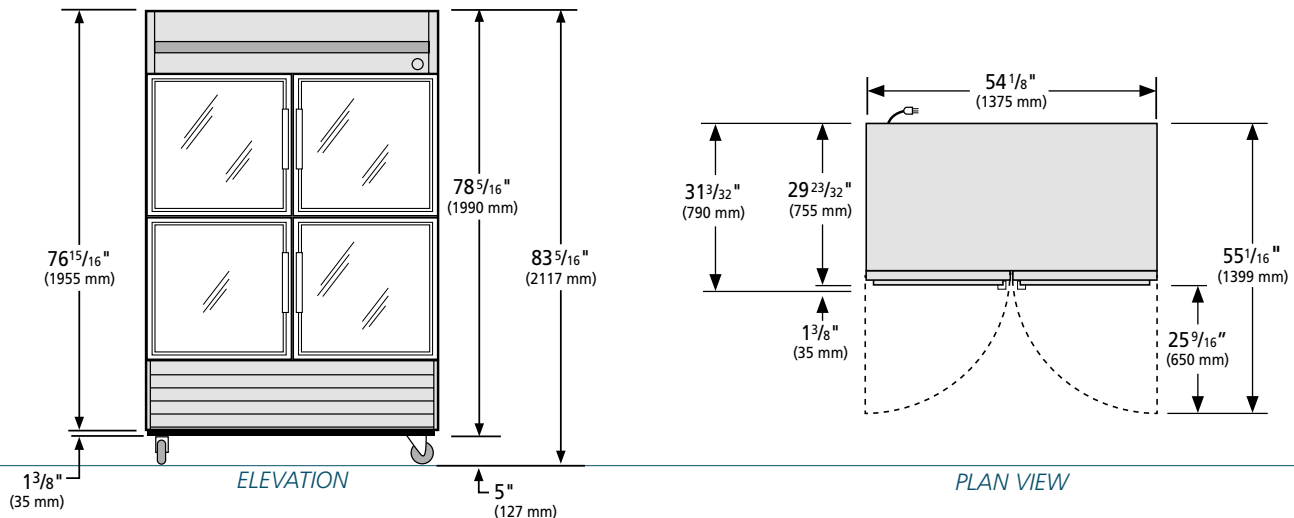

WARRANTY

One year warranty on all parts & labor and an additional 4 year warranty on compressor. (U.S.A. only)

METRIC DIMENSIONS ROUNDED UP TO THE NEAREST WHOLE MILLIMETER

SPECIFICATIONS SUBJECT TO CHANGE WITHOUT NOTICE



Model	Elevation	Right	Plan	3D
T-49G-4	TFGY05E	TFGY08S	TFEY07P	TFGY053

TRUE FOOD SERVICE EQUIPMENT

St. Charles Industrial Center • P.O. Box 970 • O'Fallon, Missouri 63366 • (636)240-2400 • FAX (636)272-2408 • (800)325-6152 • www.truemfg.com